



ProLite T1531SAW

The ProLite T1531SAW-1 uses highly accurate Surface Acoustic Wave Touch Technology (SAW) with a pure-glass scratch resistive front, offering superior image clarity and screen durability. The screen can be touched with a soft stylus, finger or gloved hand making it suitable for a number of applications, and the robust design and solid but flexible stand ensures resilience in the most demanding environment. Menu Buttons are located on the side of the screen which can be locked to prevent tampering, and include a handy function to deactivate the Touch Screen for cleaning. The iiyama ProLite T1531SAW-1 Touch Screen is ideal for a wide range of applications including Point of Sale, Kiosks, Hospitality and Entertainment, Control rooms, Education, Training and many others.

DISPLAY CHARACTERISTICS

Diagonal	15"
Touchtechnology	surface acoustic wave
Panel	TN
Glass hardness	8H minimum
Display area h x w	228 x 304 mm; 9" x 12"
Response time	8 ms
Static contrast	500 : 1 with touch panel
Brightness	300 cd/m ² max.
Brightness	230 cd/m ² with touch panel
Viewing zone	horizontal/vertical: 140°/ 125°; right/left: 70°/ 70°; up/down: 60°/ 65°
Display colour	16.7 million
Pixel pitch h x v	0.297 x 0.297 mm
Native resolution	1024 x 768 (0.8 megapixel)
Horizontal sync	31.5 - 60.2 KHz
Vertical sync	56 - 75 Hz
Synchronization	Separate Sync
Aspect ratio	4 : 3
Light transmittance	92%

POWER MANAGEMENT

Power supply	AC 100 - 240 V, 50 / 60 Hz
Power Supply Unit	internal
Power usage	20 W typical; max. 3 W in Power management mode
Power management	VESA DPMS

DIMENSIONS / WEIGHT

Dimensions w x h x d	351 x 306 x 201 mm
Weight	4.8 kg

INTERFACES / CONNECTORS / CONTROLLERS

Analog input connector	D-Sub
Digital input connector	DVI-D
Inputs	USB, RS-232C

SPECIAL FEATURES

Apple - Mac	OS9, OSX
Plug & Play	VESA DDC 2BTM
Controls	On-Screen-Display in 8 languages (DE, EN, ES, FR, IT, JP, Chinese - traditional and simplified) and 5 front controls (Menu, Scroll up/ Brightness, Scroll down/ Mute, Select/ Auto, Power)
User controls	contrast, brightness, auto adjust, H.position, V.position, H.size, phase, OSD H.position, OSD V.position, OSD timeout, reset, input select, OSD language, colour temperature, volume, mute
Speakers	2 x 1 W (Stereo)
Anti-theft-device	Kensington-lock™ prepared
Safety	CE, TÜV-Bauart, Gost-R, VCCI, IP54
Tilt angle	90° up; 5° down
VESA mounting	100 x 100 mm

ACCESORIES

Driver	Windows (7, Vista, XP, 9X, 2000, CE, NT4), Linux, Mac (OSX, OS9), DOS
Included accessories	power cable, D-Sub signal cable, DVI-D signal cable, RS-232C signal cable, audio cable, USB cable, Touch Panel Driver Disk (CD-ROM), screw, quick start guide



ProLite T1531SR is based on the latest 5 Wire Resistive technology. Price / performance ratio is ideal for the budget conscious user while quality and specification is certainly not compromised. The display inputs include both Analogue and Digital (DVI) with Touchscreen connectivity via either USB or RS-232 which offers greater than typical flexibility. A solid and steady base supports the TouchScreen with an adjustable stand offering full 90 degree angles. Extensive Touch Utilities allow for 4 point calibration and either 9/25 point linerization. An incredibly powerful Touch solution. Available in black and white.



TOUCH TECHNOLOGY - RESISTIVE

5-wire resistive touchscreens are very durable and can be used in a variety of environments. They are especially recommended for shops, restaurants and industrial purposes.



IP54

The IP Code classifies how resistant a device is to foreign objects and moisture. IP54 means that the monitor will operate in dusty conditions, and will resist splashing water.

1. DISPLAY CHARACTERISTICS

DIAGONAL	15"; 38cm
TOUCHTECHNOLOGY	resistive
PANEL	TN LED
DISPLAY AREA H X W	228 x 304 mm; 9" x 12"
RESPONSE TIME	8 ms
CONTRAST	700 : 1 with touch panel
BRIGHTNESS	350 cd/m ² typical
BRIGHTNESS	280 cd/m ² with touch panel
VIEWING ZONE	horizontal/vertical: 140° / 125° ; right/left: 70° / 70° ; up/down: 60° / 65°
DISPLAY COLOUR	16.7 million
PIXEL PITCH H X V	0.297 x 0.297 mm
NATIVE RESOLUTION	1024 x 768 (0.8 megapixel)
HORIZONTAL SYNC	31.5 - 60.2 KHz
VERTICAL SYNC	56 - 75 Hz
SYNCHRONIZATION	Separate Sync
ASPECT RATIO	4 : 3
LIGHT TRANSMITTANCE	80%

2. INTERFACES & CONNECTORS

ANALOG INPUT CONNECTOR	VGA
DIGITAL INPUT CONNECTOR	DVI-D
INPUTS	USB, RS-232C

3. SPECIAL FEATURES

APPLE - MAC	OS9, OSX
PLUG & PLAY	VESA DDC 2B™
CONTROLS	On-Screen-Display in 8 languages (DE, EN, ES, FR, IT, JP, Chinese - traditional and simplified) and 5 front controls (Menu, Scroll up/ Brightness, Scroll down/ Mute, Select/ Auto, Power)
USER CONTROLS	contrast, brightness, auto adjust, H.position, V.position, H.size, phase, OSD H.position, OSD V.position, OSD timeout, reset, input select, OSD language, colour temperature, volume, mute
SPEAKERS	2 x 1 W (Stereo)
ANTI-THEFT-DEVICE	Kensington-lock™ prepared
SAFETY	CE, CB, TÜV-Bauart, VCCI, CU, cULus, IP54
TILT ANGLE	90° up; 5° down
VESA MOUNTING	100 x 100 mm
COLOUR	White

4. ACCESSORIES

DRIVER	Windows (7, Vista, XP, 9X, 2000, CE, NT4), Linux, Mac (OSX, OS9), DOS
INCLUDED ACCESSORIES	power cable, VGA signal cable, DVI-D signal cable, RS-232C signal cable, audio cable, USB cable, Touch Panel Driver Disk (CD-ROM), screw, quick start guide

5. POWER MANAGEMENT

POWER SUPPLY	AC 100 - 240 V, 50 / 60 Hz
POWER SUPPLY UNIT	internal
POWER USAGE	20 W typical; max. 2 W in Power management mode
POWER MANAGEMENT	VESA DPMS

6. DIMENSIONS & WEIGHT

DIMENSIONS W X H X D	351 x 306 x 201 mm
WEIGHT	4.8 kg

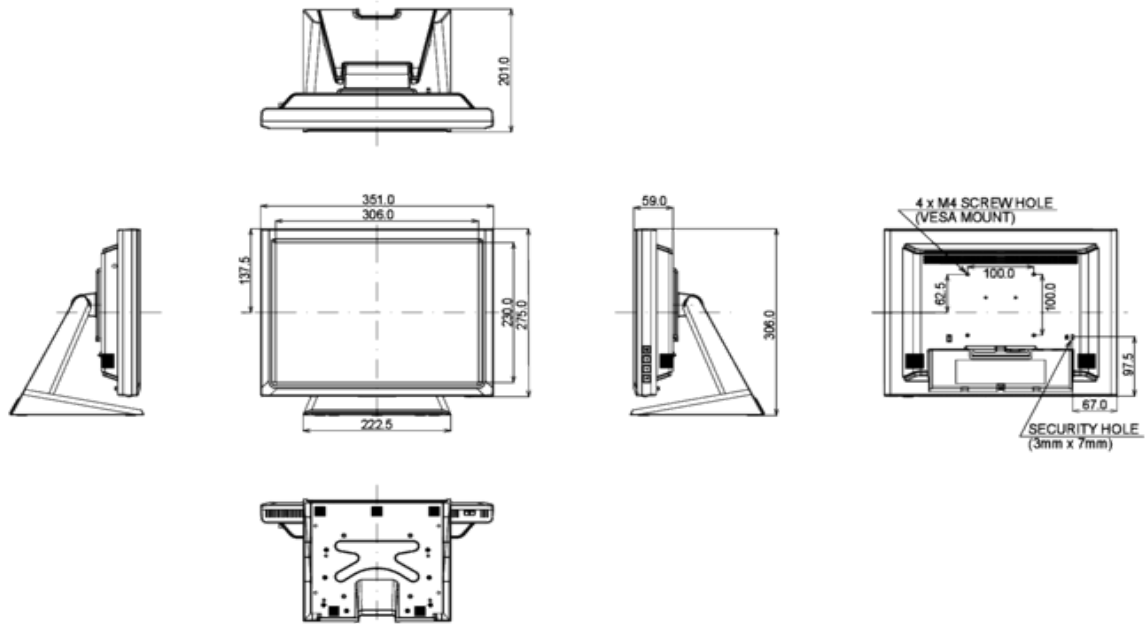

All trademarks and registered trademarks acknowledged. E & O E. Specification subject to change without notice. All LCD's comply with ISO-9241-307:2008 in connection with pixel defects.

© IYAMA CORPORATION (). ALL RIGHTS RESERVED.



15" Projective Capacitive 10pt touch screen

The ProLite T1532MSC 15" multi-touch screen is based on projected capacitive technology which thanks to a glass overlay covering the screen guarantees high durability, scratch-resistance and perfect picture performance. The touch function remains unaffected even if the glass is scratched. A solid and steady base supports the TouchScreen with an adjustable stand offering full 90 degree positioning angles. Menu Buttons are located on the side of the screen which can be locked to prevent tampering and includes a handy function to deactivate the TouchScreen for cleaning. In addition the edge-to-edge glass design creates an eye-catching finish with high light transmission guaranteeing perfect picture clarity and brilliant colours.

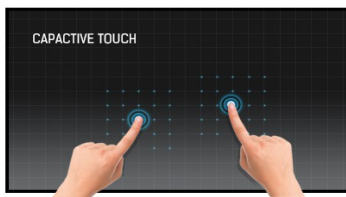

TOUCH TECHNOLOGY - CAPACITIVE

This technology uses a sensor-grid of micro-fine wires integrated into the glass that covers the screen. Touch is detected because electrical characteristics of the sensor grid change when human finger is placed on the glass. Thanks to the glass overlay this technology is highly durable, and the touch function remains unaffected even if the glass is scratched. It offers perfect picture performance and will work with human finger (gloved or not) and magnetic ball.



IP54

The IP Code classifies how resistant a device is to foreign objects and moisture. IP54 means that the monitor will operate in dusty conditions, and will resist splashing water.

1. DISPLAY CHARACTERISTICS

DIAGONAL	15"; 38cm
TOUCHTECHNOLOGY	projective capacitive, multitouch (10 compatible touch points - HID, only with supported OS), activated by finger
PANEL	TN LED
GLASS HARDNESS	7H minimum
DISPLAY AREA H X W	228 x 304 mm; 9" x 12"
RESPONSE TIME	8 ms
CONTRAST	700 : 1 with touch panel
BRIGHTNESS	350 cd/m ² typical
BRIGHTNESS	315 cd/m ² with touch panel
VIEWING ZONE	horizontal/vertical: 140° / 125° ; right/left: 70° / 70° ; up/down: 65° / 60°
DISPLAY COLOUR	16.7 million
PIXEL PITCH H X V	0.297 x 0.297 mm
NATIVE RESOLUTION	1024 x 768 (0.8 megapixel)
HORIZONTAL SYNC	31,4 - 60 KHz
VERTICAL SYNC	56 - 75 Hz
SYNCHRONIZATION	Separate Sync
ASPECT RATIO	4 : 3
LIGHT TRANSMITTANCE	90%

2. INTERFACES & CONNECTORS

ANALOG INPUT CONNECTOR	VGA
DIGITAL INPUT CONNECTOR	DVI-D
INPUTS	USB (for touch connectivity)

3. SPECIAL FEATURES

CONTROLS	On-Screen-Display in 8 languages (DE, EN, ES, FR, IT, JP, Chinese - traditional and simplified) and 5 front controls (Menu, Scroll up/ Brightness, Scroll down/ Mute, Select/ Auto, Power)
USER CONTROLS	contrast, brightness, auto adjust, H.position, V.position, H.size, phase, OSD H.position, OSD V.position, OSD timeout, reset, input select, OSD language, colour temperature, volume, mute
SPEAKERS	2 x 1 W (Stereo)
ANTI-THEFT-DEVICE	Kensington-lock™ prepared
SAFETY	CE, CB, CU, TÜV-Bauart, VCCI, cULus, IP54
TILT ANGLE	90° up; 5° down
VESA MOUNTING	100 x 100 mm
COLOUR	Black

4. ACCESSORIES

DRIVER	multi-touch: Windows7/8/10 (HID compliant), single-touch: Vista, XP, 9X, 2000, CE, NT4, Linux, Mac (OSX)
INCLUDED ACCESSORIES	power cable, VGA (D-Sub) signal cable, DVI-D signal cable, audio cable, USB cable, Touch Panel Driver Disk (CD-ROM), screw, quick start guide, safety guide

5. POWER MANAGEMENT

POWER SUPPLY	AC 100 - 240 V, 50 / 60 Hz
POWER SUPPLY UNIT	internal
POWER USAGE	20 W typical; max. 2 W in Power management mode
POWER MANAGEMENT	VESA DPMS

6. DIMENSIONS & WEIGHT

DIMENSIONS W X H X D	351 x 306.5 x 202 mm
WEIGHT	4.5 kg

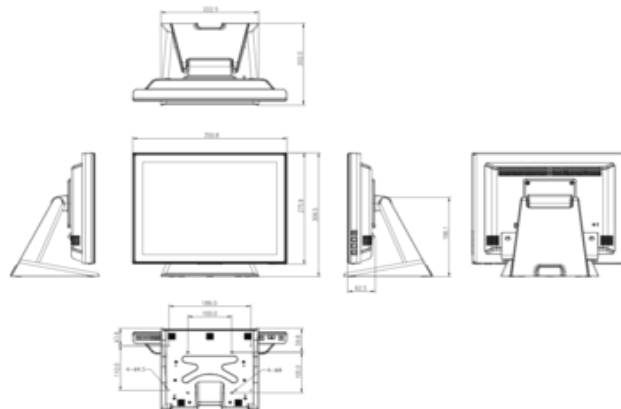

All trademarks and registered trademarks acknowledged. E & O E. Specification subject to change without notice. All LCD's comply with ISO-9241-307:2008 in connection with pixel defects.

ProLite T1532SR



ProLite T1532SR is an incredibly powerful touch solution based on the latest 5 Wire Resistive technology. Price / performance ratio is ideal for the budget conscious user while quality and specification is certainly not compromised. The display inputs include both Analogue and Digital (DVI) with Touchscreen connectivity via either USB or RS-232 which offers greater than typical flexibility. A solid and steady base supports the TouchScreen with an adjustable stand offering full 90 degree positioning angles. Extensive Touch Utilities allow for 4 point calibration and 9/25 point linerisation. Menu Buttons are located on the side of the screen which can be locked to prevent tampering, and includes a handy function to deactivate the Touch Screen for cleaning. In addition the bezel free design creates an eye-catching finish with high light transmission guaranteeing perfect picture clarity and brilliant colours.

DISPLAY CHARACTERISTICS

Diagonal	15"
Touchtechnology	resistive
Panel	TN
Display area h x w	228 x 304 mm; 9" x 12"
Response time	8 ms
Static contrast	500 : 1 with touch panel
Brightness	200 cd/m ² with touch panel
Viewing zone	horizontal/vertical: 140° / 125°; right/left: 70° / 70°; up/down: 60° / 65°
Display colour	16.7 million
Pixel pitch h x v	0.297 x 0.297 mm
Native resolution	1024 x 768 (0.8 megapixel)
Horizontal sync	31.5 - 60.2 KHz
Vertical sync	56 - 75 Hz
Synchronization	Separate Sync
Aspect ratio	4 : 3
Light transmittance	80%
Type	bezel-free

POWER MANAGEMENT

Power supply	AC 100 - 240 V, 50 / 60 Hz
Power Supply Unit	internal
Power usage	20 W typical; max. 2 W in Power management mode
Power management	VESA DPMS

DIMENSIONS / WEIGHT

Dimensions w x h x d	351 x 306 x 201 mm
Weight	4.8 kg

INTERFACES / CONNECTORS / CONTROLLERS

Analog input connector	VGA (D-SUB)
Digital input connector	DVI-D
Inputs	USB, RS-232C D-Sub, DVI-D

SPECIAL FEATURES

Apple - Mac	OS9, OSX
Plug & Play	VESA DDC 2B™
Controls	On-Screen-Display in 8 languages (DE, EN, ES, FR, IT, JP, Chinese - traditional and simplified) and 5 front controls (Menu, Scroll up/ Brightness, Scroll down/ Mute, Select/ Auto, Power)
User controls	contrast, brightness, auto adjust, H.position, V.position, H.size, phase, OSD H.position, OSD V.position, OSD timeout, reset, input select, OSD language, colour temperature, volume, mute
Speakers	2 x 1 W (Stereo)
Anti-theft-device	Kensington-lock™ prepared
Safety	CE, TÜV-Bauart, Gost-R, VCCI, IP54
Tilt angle	90° up; 5° down
VESA mounting	100 x 100 mm

ACCESORIES

Driver	Windows (7, Vista, XP, 9X, 2000, CE, NT4), Linux, Mac (OSX, OS9), DOS
Included accessories	power cable, D-Sub signal cable, DVI-D signal cable, RS-232C signal cable, audio cable, USB cable, Touch Panel Driver Disk (CD-ROM), screw, quick start guide



multisystems

Η multisystems διανέμει και υποστηρίζει τεχνικά, προϊόντα από τους μεγαλύτερους οίκους κατασκευής σε Barcode scanners, εκτυπωτές ετικετών, φορητά τερματικά, λύσεις πλαστικών καρτών τύπου πιστωτικής καθώς και συστήματα λιανικής πώλησης όπως συστήματα Point of sale, ταμειακές μηχανές και φορολογικούς μηχανισμούς.

Στις εγκαταστάσεις μας στο Αιγάλεω λειτουργεί πλήρως εξοπλισμένο τεχνικό εργαστήριο με άρτια καταρτισμένους μηχανικούς που μπορούν να δώσουν λύσεις ακόμα και στις πιο δύσκολες μηχανογραφικές προκλήσεις του χώρου της βιομηχανίας, της εφοδιαστικής αλυσίδας και της λιανικής.

Σας εξυπηρετούμε έναν – έναν προσωπικά προσφέροντας σας τον προσωπικό σας τεχνικό σύμβουλο ο οποίος γνωρίζει τις ανάγκες και τις ιδιαιτερότητες της επιχείρησής σας ενώ σας εξυπηρετεί σε όλη την πορεία της συνεργασίας σας μαζί μας ή εξέλιξης του έργου σας. Είμαστε δίπλα σας να σας συμβουλέψουμε να επιλέξετε τον σωστό εξοπλισμό μέσα από μια ευρύτατη γκάμα 12.000 προϊόντων τεχνολογίας για όλες τις ανάγκες από τα πιο επώνυμα εργοστάσια της παγκόσμιας αγοράς.

Για την καλύτερη εξυπηρέτησή σας έχουμε διαχωρίσει τα εμπορικά και τα τεχνικά μας τμήματα σε 6 διακριτές ενότητες τις οποίες μπορείτε να δείτε στον πίνακα που ακολουθεί προκειμένου να σας εξυπηρετούμε γρήγορα και αποτελεσματικά. Για οτιδήποτε χρειαστείτε μην διστάσετε να επικοινωνήσετε μαζί μας στο **211 780 1000**, θα χαρούμε να σας εξυπηρετήσουμε.

Η multisystems διαθέτει και υποστηρίζει



Barcode scanners

Ενσύρματα | Ασύρματα | 2D Imagers | Bluetooth IOS / Android | Λιανικής



Εκτυπωτές ετικετών & αναλώσιμα

Επιτραπέζιοι | Βιομηχανικοί | Έγχρωμοι | Ετικέτες | Μελανοταινίες



Φορητά τερματικά

Φορητά τερματικά | Βιομηχανικά Tablets | Τερματικά αυτοκινήτου / Κλαρκ



Συστήματα λιανικής πώλησης Point of sale

Συστήματα POS | Touchscreen οθόνες | Θερμικοί εκτυπωτές



Λύσεις πλαστικών καρτών

Εκτυπωτές πλαστικών καρτών | Αναλώσιμα | Πλαστικές κάρτες PVC



Φορολογικά προϊόντα

Ταμειακές μηχανές | Φορολογικοί μηχανισμοί | Φορολογικοί εκτυπωτές

Συνεργαζόμενοι οίκοι

DATALOGIC

ZEBRA

hp Gold Partner

Honeywell

PERFORMANCE PARTNER PROGRAM SILVER LEVEL

EPSON AUTHORISED PARTNER 2015

Intermec®

do™

datamax • o'neil

elo TOUCH SOLUTIONS

socket® mobile

evolis card printers

AVATO

CITIZEN Micro HumanTech



multisystems

ACR Electronics ΕΠΕ

Λεωφ. Θηβών 339, 122 43, Αιγάλεω

<http://www.multisystems.gr> | info@multisystems.gr

Tel. 211 780 1000 Fax 211 780 2000